

# FMP SERIES

**I**N-LINE FILTER



Maximum working pressure 4000 psi

Flow rate to 140 gpm

# FMP

## SERIES

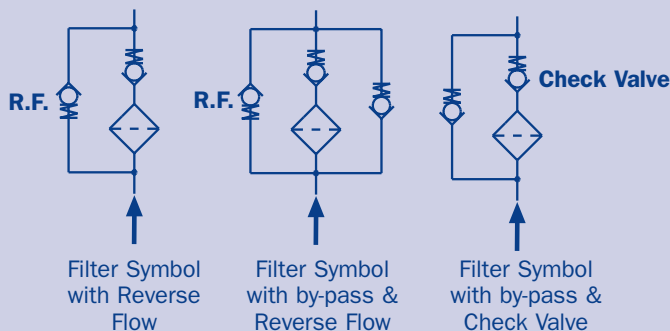
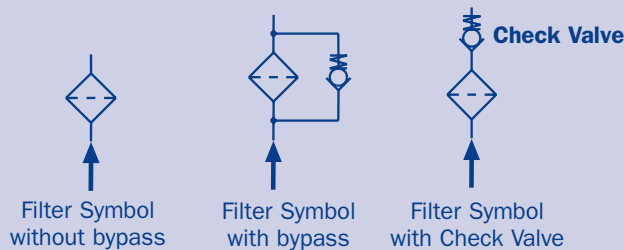

**FMP** series filters are designed for pressure line applications and are suitable for in-line installation. This series of filters has been developed to satisfy the medium working pressure sector of the pressure filter market. Continued research and development on both the filter bodies and the filter elements has resulted in a product line featuring a compact light weight housing combined with a high filtration efficiency. The transverse bypass valve is a standard feature with this range of product. (Non bypass for servo applications is also available).

A complete line of pressure differential visual and electrical indicators are available with this series of filters.

**FMP** series filters are available with Reverse Flow Valve. Flow rates are restricted for reverse flow and check valve application.

**FMP** series are specifically designed for mobile, agricultural and industrial applications.

### Internal check valve option

This series of filters can be supplied with an internal check valve. The valve eliminates the need for an externally fitted valve. Installing this valve, will prevent excessive fluid loss when changing elements and reduce air entrapment within the system. Refer to page 4 for specification

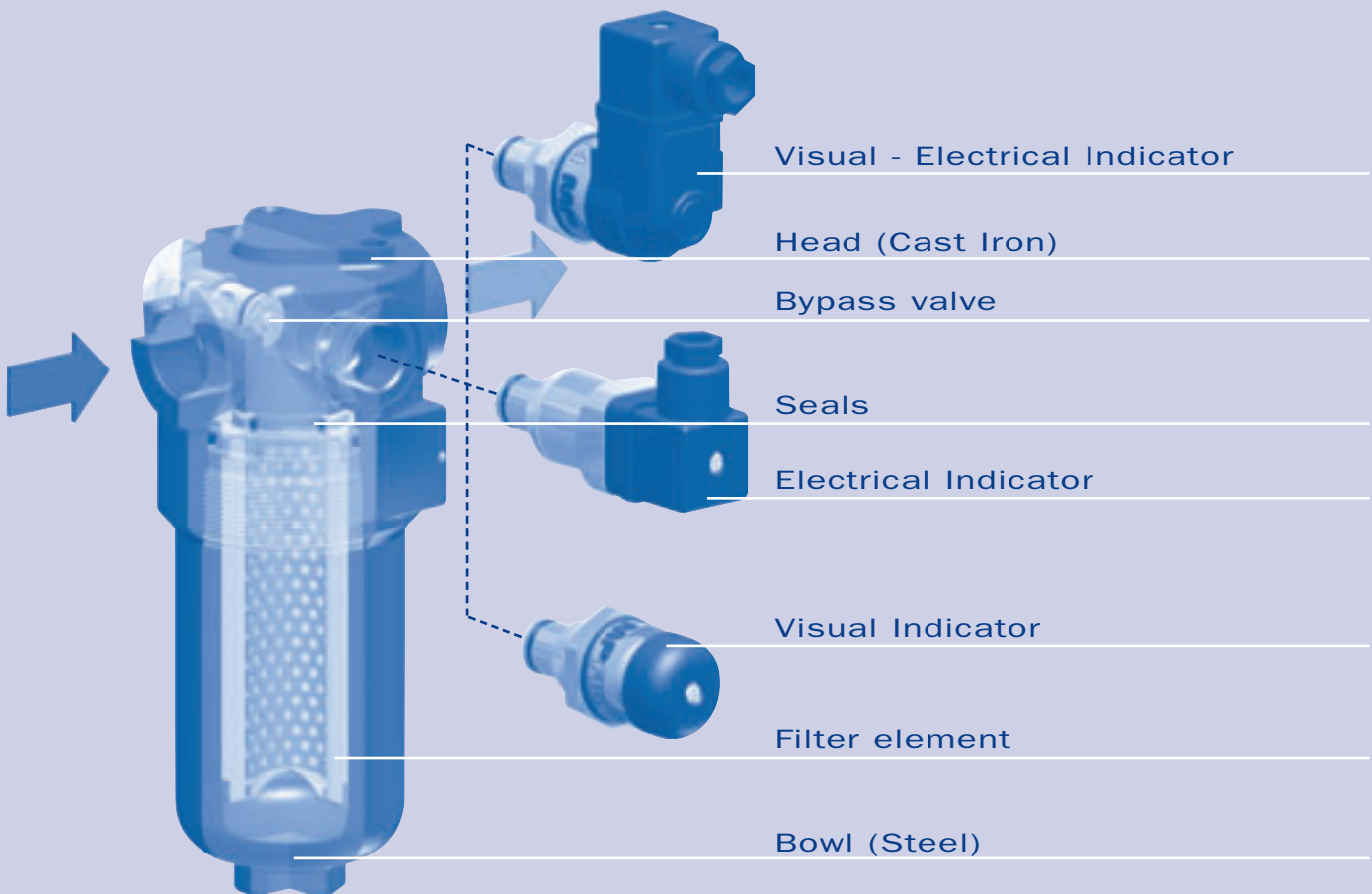

### Filter body (Material)

- Head: Cast iron
- Bowl: Steel
- By-pass valve : Brass
- Reverse Flow : Steel (Only for 135 -320 series)
- Check valve : Steel

### Pressure filter body

- Working pressure: 4000 psi (28 MPa)
- Test pressure: 5075 psi (35 MPa)
- Burst pressure: 10,875 psi (75 MPa)
- Fatigue test: 1.000.000 cycles with pressure pulses from 0 to max. working pressure

### Working Temperature

- from -13°F to + 230°F

### Bypass valve

- Bypass valve setting 90 psi ±10%
- Other pressure settings available.

### Filter elements - Collapse pressure

- N series: 285 psi
- H series: 3045 psi
- M series: 285 psi

### Seals

- Standard Buna-N A series
- Optional Viton V series

### Compatibility with fluids

- Housing, compatible for use with: Mineral oil according to ISO 2943 - water-based emulsions-synthetic fluids - water- glycol.
- Elements, compatible for use with mineral oil according to ISO 2943, synthetic fluids, water-based emulsions and water-glycol.
- Seals in Nitrile (Buna-N) A series, compatible with: Mineral oil according to ISO 2943 - water-based emulsions-water- glycol.
- Seals in Viton V series, compatible with: Synthetic fluids type HS-HFDR-HFDS-HFDU

### Weights (lbs)

### Lengths

	1	2	3	4
• FMP 065	8,6	9,3	12,6	-
• FMP 135	16,5	20,7	26,0	-
• FMP 320	28,0	32,4	45,6	52.14

### Filter volume (in<sup>3</sup>)

### Lengths

	1	2	3	4
• FMP 065	22	25	37	-
• FMP 135	34	52	74	-
• FMP 320	77	120	170	213

### Port connections

**FMP 065** See page 6

**FMP 135** See page 7

**FMP 320** See page 8

### MP filter elements, conform to the following ISO standard:

- ISO 2941 - Verification of collapse/burst resistance.
- ISO 2942 - Verification of fabrication integrity and determination of the first bubble point.
- ISO 2943 - Verification of material Compatibility with fluids.
- ISO 3723 - Method for end load test.
- ISO 3724 - Verification of flow fatigue characteristics.
- ISO 3968 - Evaluation of pressure drop versus flow characteristics.
- ISO 16889- Multi-pass method for evaluating filtration performance.

### Filtering area

Filter element type	Values in in <sup>2</sup>			
	1	2	3	4
<b>N</b> (Δp 285 psi)				
<b>HP065</b>	60	85	170	-
<b>HP135</b>	139	291	380	-
<b>HP320</b>	234	515	841	1169
<b>H</b> (Δp 3045 psi)				
<b>HP065</b>	60	84	170	-
<b>HP135</b>	120	257	370	-
<b>HP320</b>	228	505	828	1150
<b>M</b> (Δp 285 psi)				
<b>HP065</b>	58	82	165	-
<b>HP135</b>	147	313	418	-
<b>HP320</b>	255	565	926	1284

### Electrical indicators

K - E - N Series		
Supply voltage 50/60 Hz	Resistive load	Inductive load
(V)	(A)	(A)
Vca 125 (~)	5	5
Vca 250 (~)	5	5
Vcc 30 (=)	5	3
Vcc 125 (=)	0,5	0,03
Vcc 250 (=)	0,25	0,03

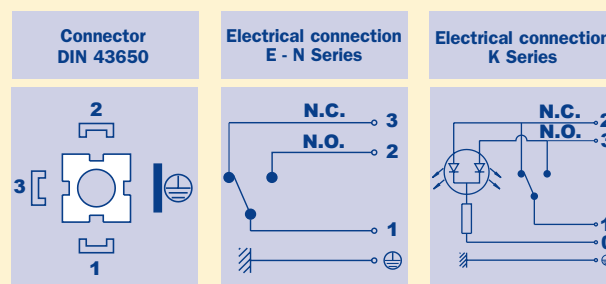

## General - Filter selection

For a quick reference guide, refer to page 6, 7 & 8.

### Filter assembly pressure drop:

$\Delta p$  Total =  $\Delta p$  filter housing +  $\Delta p$  filter element

- Housing pressure drop:  
The  $\Delta p$  is proportional to the fluid density.
- Filter element pressure drop:  
The  $\Delta p$  is proportional to the kinematic viscosity.

The pressure drop data of the filter elements reported in this brochure were obtained using mineral oil fluid @ a kinematic viscosity of 150 SUS.

## Technical data

The curves were obtained using a mineral oil with a density of 0,86 kg/dm<sup>3</sup> according to ISO 3968.

The  $\Delta p$  is proportional to the fluid density.

### Housing pressure drop

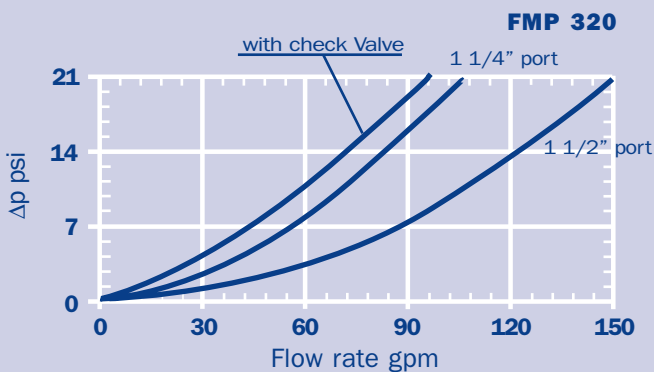
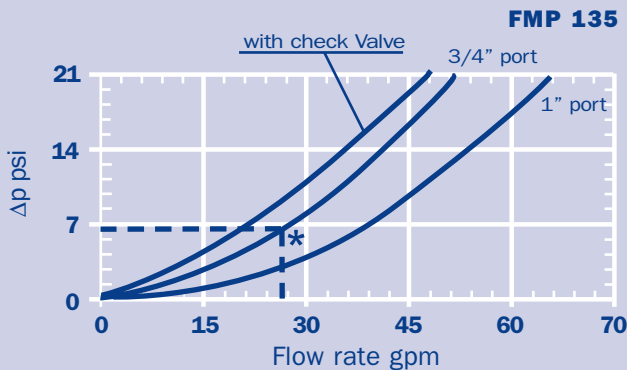
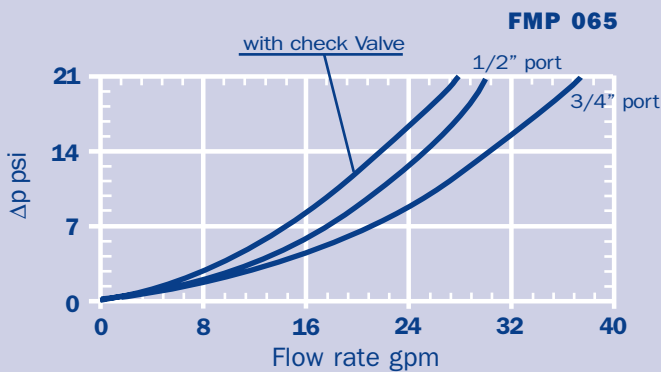

## Filter Selection

### Filter assembly sizing example

- $\Delta p$  Total
- $\Delta p_c$  Filter housing
- $\Delta p_e$  Filter element
- Y Factor
- Q gpm = Flow rate
- V1 = Reference viscosity 150 SUS
- V2 = Working viscosity in SUS

$$\Delta p \text{ Total} = \Delta p_c + \Delta p_e$$

$$\Delta p_e = Y \times Q \times (V_2/V_1)$$

### Sizing Example

- Q = 26 gpm
- V<sub>2</sub> = 230 SUS at 104°F
- P<sub>max</sub> = 3000 psi
- Filtration = 16  $\mu$ m absolute
- $\Delta p$  Total max = 21 psi (recommendation)
- Collapse pressure filter element  $\Delta p_{max}$  285 psi
- $\Delta p_c = 6.7$  psi (\* see FMP 135 diagram)
- $\Delta p_e = 0.34 \times 26 \times (230/150) = 13.75$  psi
- $\Delta p \text{ Total} = 6.7 + 13.75 = 20.45$  psi

### Filter selected

FMP 135 length 2 with A16 filter element

## HP 065 -Element technical data

For application with kinematic viscosity's other than 150 SUS - see below

"Y" factor for the pressure drop of the individual filter elements

Filter element	Y Factor Filter Element N series	Y Factor Filter Element H series	Filter Lengths
A03	3.16	3.36	1
A06	2.35	3.16	
A10	1.25	1.44	
A16	1.06	1.17	
A25	0.57	0.67	
M25	0.069	-	2
A03	2.30	2.32	
A06	1.38	1.98	
A10	0.87	0.95	
A16	0.75	0.78	
A25	0.39	0.48	3
M25	0.056	-	
A03	1.11	1.11	
A06	0.86	0.91	
A10	0.44	0.46	
A16	0.37	0.38	3
A25	0.21	0.22	
M25	0.031	-	

## HP 135 - Element technical data

For application with kinematic viscosity's other than 150 SUS - see below

"Y" factor for the pressure drop of the individual filter elements

Filter element	Y Factor Filter Element N series	Y Factor Filter Element H series	Filter Lengths
A03	1.10	1.57	1
A06	1.01	1.37	
A10	0.52	0.70	
A16	0.47	0.67	
A25	0.26	0.32	
M25	0.15	-	
A03	0.60	0.77	2
A06	0.55	0.60	
A10	0.35	0.42	
A16	0.34	0.41	
A25	0.12	0.24	
M25	0.060	-	
A03	0.35	0.48	3
A06	0.34	0.40	
A10	0.18	0.26	
A16	0.17	0.22	
A25	0.11	0.16	
M25	0.054	-	

## HP 320 - Element technical data

Filter element	Y Factor Filter Element N series	Y Factor Filter Element H series	Filter Lengths
A03	0.58	0.70	1
A06	0.52	0.66	
A10	0.27	0.37	
A16	0.20	0.34	
A25	0.14	0.18	
M25	0.056	-	
A03	0.24	0.35	2
A06	0.21	0.28	
A10	0.95	0.16	
A16	0.08	0.15	
A25	0.047	0.093	
M25	0.038	-	
A03	0.15	0.22	3
A06	0.11	0.17	
A10	0.057	0.10	
A16	0.047	0.096	
A25	0.042	0.064	
M25	0.033	-	
A03	0.11	0.17	4
A06	0.096	0.14	
A10	0.053	0.097	
A16	0.042	0.092	
A25	0.030	0.092	
M25	0.026	-	

## Valves

### Bypass valve pressure drop

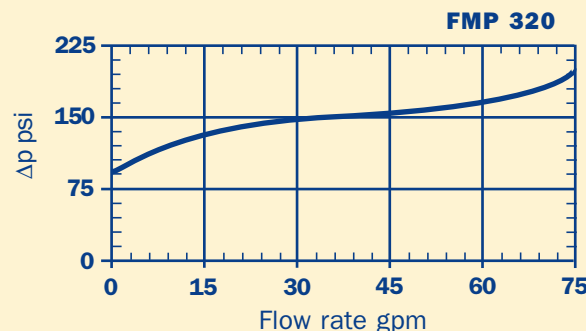
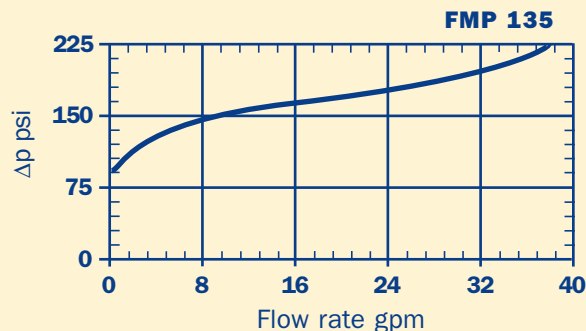
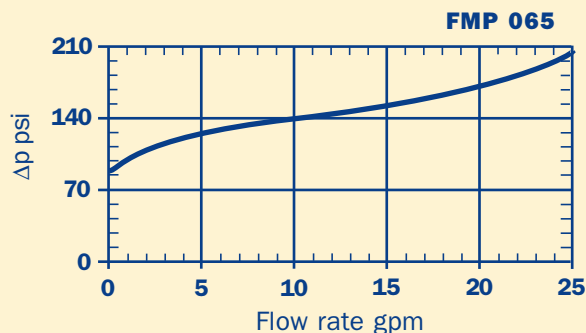

### Reverse Flow valve pressure drop

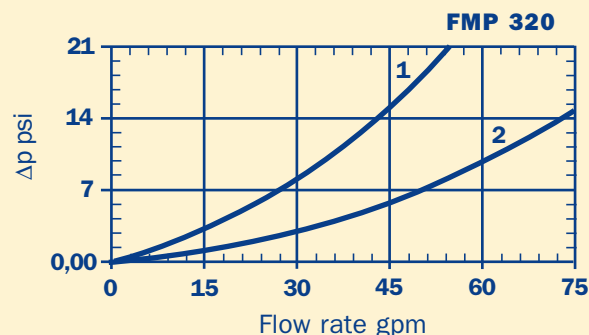
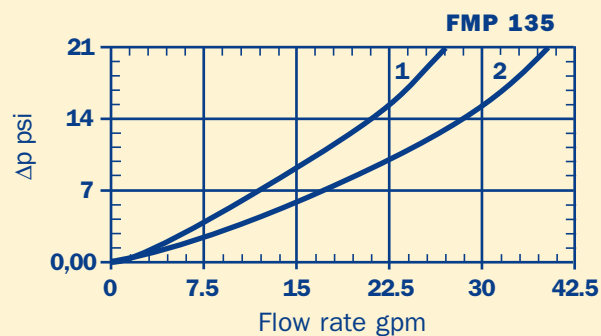

1 - Reverse Flow  
2 - Forward Flow

## FMP 065

### Indicator options

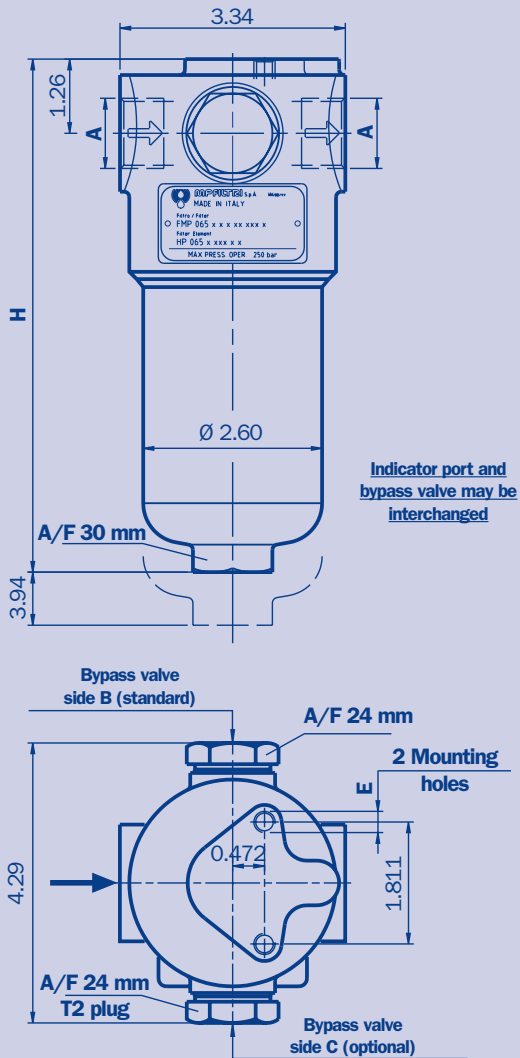
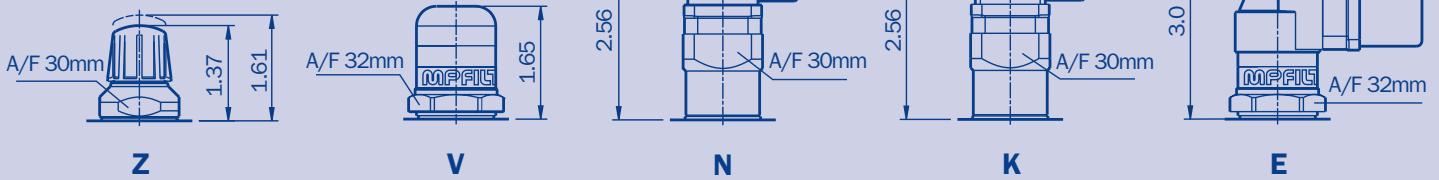

**Note:** All dimensions in inches unless noted

### Filter selection-quick reference guide

The following filter sizing recommendations are based on using a mineral oil fluid @ 150 SUS with a maximum filter assembly (housing & filter element) pressure drop of 21 psi.

Filter element type	Flow rate gpm N Series	Flow rate gpm H Series	Port Size	Filter Length	H
A03	5.5	5	1/2"	1	7.9"
A06	7	5.5			
A10	14	12			
A16	15	14			
A25	19	18			
M25	25	-	3/4"	2	9.1"
A03	8.5	8			
A06	13	9			
A10	18	16			
A16	20	19			
A25	25	23	3/4"	3	13.0"
M25	27	-			
A03	15	14			
A06	20	18			
A10	23	21			
A16	27	24			
A25	29	26.5			
M25	30	-			

### Thread connections

Connection A
1/2" BSP
1/2" NPT
3/4" BSP
3/4" NPT
SAE 8 (3/4"- 16 UNF)
SAE 12 (1-1/16"- 12 UN)

Mounting Holes E
M8
5/16" UNC
M8
5/16" UNC
5/16" UNC
5/16" UNC

# FMP 135

## Indicator options

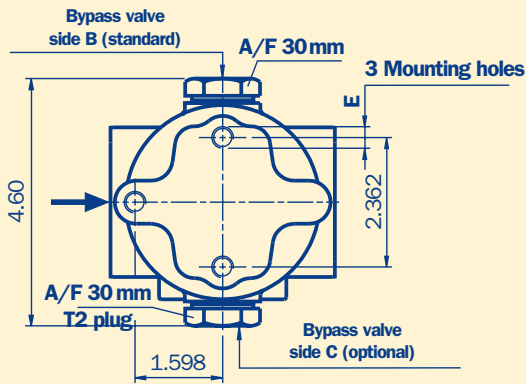
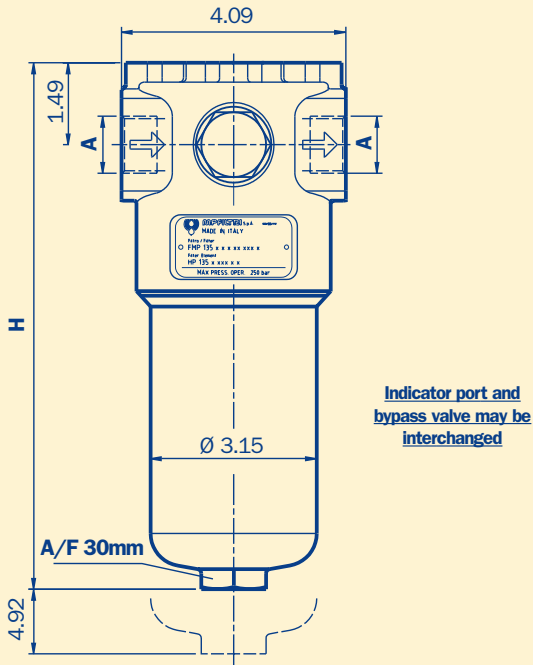
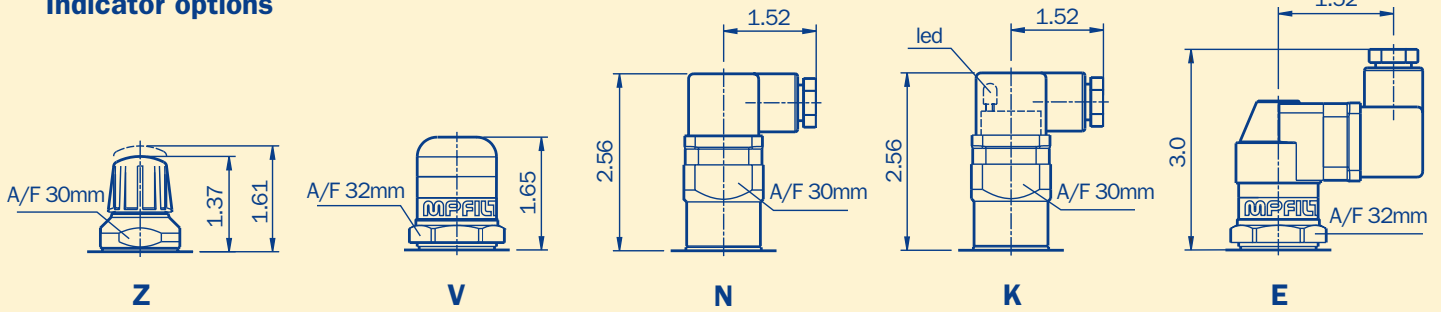

## Flange connections

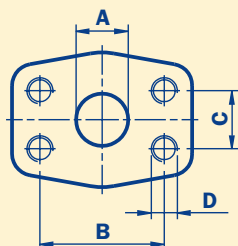

## Filter selection-quick reference guide

The following filter sizing recommendations are based on using a mineral oil fluid @ 150 SUS with a maximum filter assembly (housing & filter element) pressure drop of 21 psi.

Filter element type	Flow rate gpm N Series	Flow rate gpm H Series	Port Size	Filter Length	H
A03	15.5	12	3/4"	1	10.2"
A06	17	13			
A10	26	22			
A16	29	23.5			
A25	35.5	33			
M25	41	-	1"	2	14.8"
A03	26	22			
A06	29	26			
A10	37	34			
A16	39	37			
A25	53	45	1"	3	17.7"
M25	58	-			
A03	37	33			
A06	39.5	37			
A10	47.5	45			
A16	50	47.5	1"	3	17.7"
A25	55.5	51.5			
M25	60.5	-			

## Thread connections

Connection	Mounting Holes
<b>A</b>	<b>E</b>
3/4" BSP	M10
3/4" NPT	3/8" UNC
1" BSP	M10
1" NPT	3/8" UNC
SAE 12 (1-1/16" 12 UN)	3/8" UNC
SAE 16 (1-5/16" 12 UN)	3/8" UNC

## Flange connections

A Connection	B	C	D	E
3/4" SAE-3000 psi/M	1.875	0.875	M10	M10
3/4" SAE-3000 psi/UNC	1.875	0.875	3/8" UNC	3/8" UNC
1" SAE-3000 psi/M	2.061	1.031	M10	M10
1" SAE-3000 psi/UNC	2.061	1.031	3/8" UNC	3/8" UNC

Note: All dimensions in inches unless noted

# FMP 320

## Indicator options

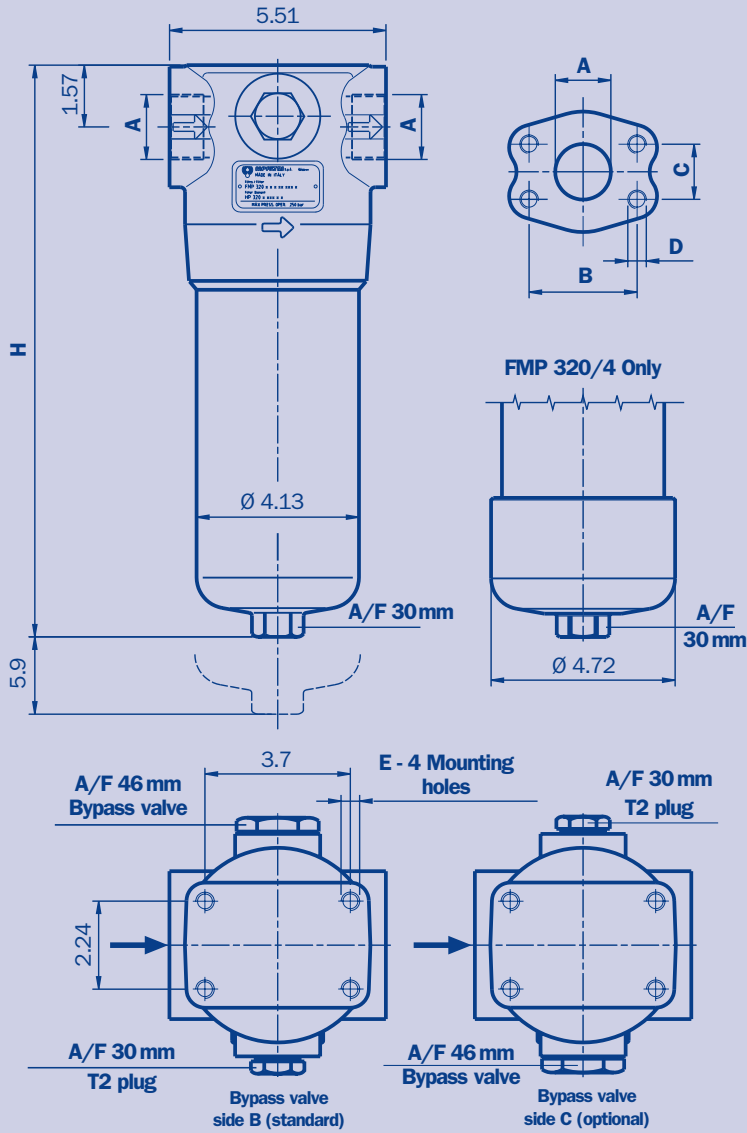
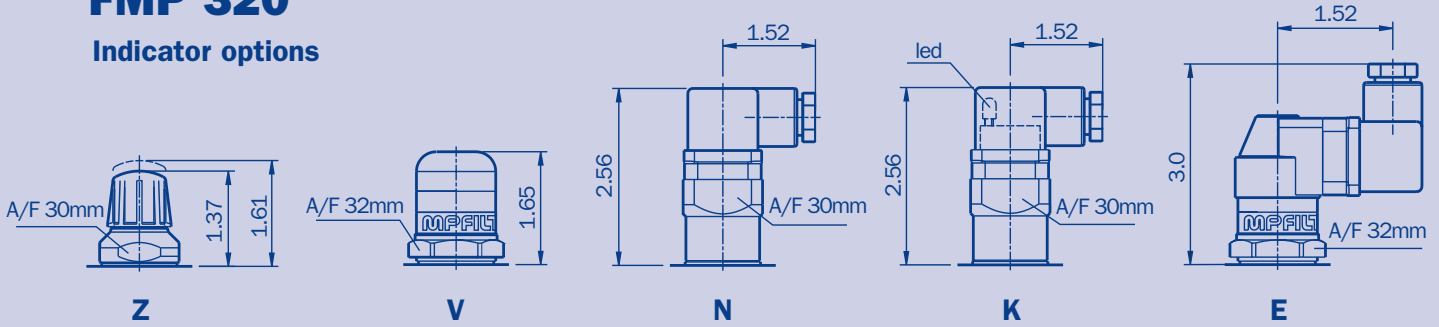

## Filter selection-quick reference guide

The following filter sizing recommendations are based on using a mineral oil fluid @ 150 SUS with a maximum filter assembly (housing & filter element) pressure drop of 21 psi.

Filter element type	Flow rate gpm N Series	Flow rate gpm H Series	Port Size	Filter Length	H
A03	29	26	1 1/4"	1	11.8"
A06	33	28			
A10	53	42			
A16	63	50			
A25	74	66			
M25	92	-	1 1/2"	2	16.5"
A03	66	52			
A06	74	58			
A10	105	82			
A16	113	87			
A25	121	105	1 1/2"	3	22.1"
M25	126	-			
A03	92	74			
A06	100	84			
A10	119	105			
A16	127	110	1 1/2"	4	26.8"
A25	129	120			
M25	135	-			
A03	99	83			
A06	108	90			
A10	127	110	1 1/2"	4	26.8"
A16	129	113			
A25	132	125			
M25	140	-			

## Thread connections

Connection	Mounting Holes
<b>A</b>	<b>E (0.59)</b>
1 - 1/4" BSP	M12
1 - 1/4" NPT	M12
1 - 1/2" BSP	1/2" UNC
1 - 1/2" NPT	1/2" UNC
SAE 20 (1 - 5/8" 12 UN)	1/2" UNC
SAE 24 (1 - 7/8" 12 UN)	1/2" UNC

## Flange connections

A Connection	B	C	D	E
1-1/4" SAE-3000 psi/M	2.311	1.188	M10	M12
1-1/4" SAE-3000 psi/UNC	2.311	1.188	7/16" UNC	1/2" UNC
1-1/2" SAE-3000 psi/M	2.75	1.405	M12	M12
1-1/2" SAE-3000 psi/UNC	2.75	1.405	1/2" UNC	1/2" UNC

**Multipass method for evaluating Filtration performance according to ISO 16889. ISO MTD text dust**

Dimensions for β values	2	10	75	100	200	1000
Efficiency in %	50%	90%	98,70%	99%	99,50%	99,90%

Elements media	(µm ©)					
A03	<3	<3	<3	<3	3,30	4,2
A06	<3	<3	4,31	4,53	5,07	6,3
A10	<6	<6	6,12	6,41	7,12	9,0
A16	<7	<7	10,45	10,97	12,13	13,9
A25	<9	12,34	15,82	16,30	17,46	19,3

Multipass method for evaluating Filtration performance according to ISO 4572. ACFTD text dust

Dimensions for β values	200
Efficiency in %	99,50%

	µm
A03	3 µm
A06	6 µm
A10	10 µm
A16	16 µm
A25	25 µm

The data are reported to a value of final Δp equal to 16 bar

**Comparison**

ISO MTD (µm©)	4	6	14	21
ACFTD (µm)	<1	5	15	25

**Characteristics of the filter element with nominal filtration M / T series**

Square wire mesh filtration degree is defined in microns by the maximum diameter of a sphere corresponding to the mesh size.

**Hydraulic System Component Cleanliness Levels**

System component	Typical Cleanliness Specification									
	12/10/7	13/11/8	14/12/9	15/13/10	16/14/11	17/15/12	18/16/13	19/17/14	20/18/15	
Servo valve			●	●	●					
Proportional valve				●	●	●				
Variable pump					●	●	●			
Cartridge valve						●	●	●		
Fixed piston pump						●	●	●		
Vane pump							●	●	●	
Pressure/flow control valve							●	●	●	
Solenoid valve							●	●	●	
ISO cleanliness	12/10/7	13/11/8	14/12/9	15/13/10	16/14/11	17/15/12	18/16/13	19/17/14	20/18/15	
NAS cleanliness	1	2	3	4	5	6	7	8	9	
Recommended absolute element rating	3 micron			6 micron			10 micron		>10	

Absolute filter elements have been tested by the following independent institutes.

Institute of Filtration  
(France)



KUNGL  
TEKNISKA  
HÖGSKOLAN

Royal Institute of Technology



## Filter assembly FMP



Example: FMP 065 2 B A G1 A10 N P01 / V7

## Filter element HP



Example: HP065 2 A10 A N P01

### 1 - Size

065	FMP 065
135	FMP 135
320	FMP 320

### 2 - Filter Length

1	
2	
3	
4	(Only for 320 series)

### 3 - Valve

S	Without bypass
B	With bypass (standard)
C	With bypass (optional)
D	With bypass B & check valve
V	With reverse flow * (Only for 135 - 320 series)
R	With reverse flow + bypass * (Only for 135 - 320 series)
T	With Check valve only *

\*Restricted Flow Rate

### 4 - Seals

A	Buna-N
V	Viton
E	EPDM

### 5 - Port options

TYPE	065	135	320
G1	1/2" BSP	3/4" BSP	1-1/4" BSP
G2	3/4" BSP	1" BSP	1-1/2" BSP
G3	1/2" NPT	3/4" NPT	1-1/4" NPT
G4	3/4" NPT	1" NPT	1-1/2" NPT
G5	SAE 8 (3/4" - 16 UNF)	SAE 12 (1-1/16" - 12 UN)	SAE 20 (1-5/8" - 12 UN)
G6	SAE 12 (1-1/16" - 12 UN)	SAE 16 (1-5/16" - 12 UN)	SAE 24 (1-7/8" - 12 UN)
F1	-	3/4" SAE 3000 PSI/M	1-1/4" SAE 3000 PSI/M
F2	-	1" SAE 3000 PSI/M	1-1/2" SAE 3000 PSI/M
F3	-	3/4" SAE 3000 PSI/UNC	1-1/4" SAE 3000 PSI/UNC
F4	-	1" SAE 3000 PSI/UNC	1-1/2" SAE 3000 PSI/UNC

### 6 - Filter elements

A03	Fiberglass 3 µm
A06	Fiberglass 6 µm
A10	Fiberglass 10 µm
A16	Fiberglass 16 µm
A25	Fiberglass 25 µm
M25	Square wire mesh

### 7 - Collapse pressure series

N	285 psi
H	3000 psi

### 8 - Filter assembly type

P01	MP Filtri standard
Pxx	Customer request

### 9 - indicators

Z7	Visual (Pop-up) 75 psi	N7	Electrical 75 psi	K7*	Visual-electrical 75 psi
Z8	Visual (Pop-up) 100 psi	N8	Electrical 100 psi	K8*	Visual-electrical 100 psi
V7	Visual 75 psi	E7	Visual-electrical 75 psi		
V8	Visual 100 psi	E8	Visual-electrical 100 psi		

\* { 1 - 24 Volt  
2 - 110 Volt  
3 - 220 Volt

MP Filtri - Filtration products will only be guaranteed if original MP Filtri replacement elements and spares are used



**Head Quarter :**

**MP FILTRI S.p.A. Italy**

Via Matteotti, 2  
20060 Pessano con Bornago (Milano) Italy  
Tel. ++39.02/95703.1  
Fax ++39.02/95741497-95740188  
email: sales@mpfiltri.com  
<http://www.mpfiltri.com>

**GREAT BRITAIN**

**MP FILTRI U.K. Ltd.**

Bourton Industrial Park  
Bourton on the Water  
Gloucestershire GL54 2HQ UK  
Phone: 01451-822522  
Fax: 01451-822282  
email: sales@mpfiltri.co.uk  
<http://www.mpfiltri.co.uk>



**GERMANY**

**MP FILTRI D GmbH**

Am Wasserturm 5  
D-66265 Heusweiler/Holz  
Phone: 06806/85022-0  
Fax: 06806/85022-18  
email: mpfiltrink@aol.com

**FRANCE**

**MP FILTRI FRANCE**

B.P. 325  
01603 Trevoux Cedex  
Tel: 04.74.08.84.78  
Telefax: 04.74.08.80.45  
email: mpfiltrifrance@wanadoo.fr

**USA**

**MP FILTRI USA Inc.**

2055 Quaker Pointe Drive  
Quakertown, PA 18951  
Phone: 215-529-1300  
Fax: 215-529-1902  
email: mpusasales@aol.com  
<http://www.mpfiltriusa.com>

**CANADA**

**MP FILTRI CANADA Inc.**

210 Jacob Keffer Parkway Concord,  
Ontario Canada L4K 4W3  
Phone: 905-303-1369  
Fax: 905-303-7256  
email: mail@mpfiltricanada.com  
<http://www.mpfiltricanada.com>